

Grasshoppers as Pests

Grasshoppers consume considerable amounts of foliage during their nymphal development, and also as adults. When they are especially abundant they can damage economically important plants. In Florida, *Romalea microptera* and *Schistocerca americana* are the most serious grasshopper pests, occasionally damaging vegetables, citrus, and ornamental plants. Several other species cause minor damage to forage, field, and ornamental crops. Grasshoppers in Florida rarely gain the notoriety that they have attained in states west of the Mississippi River, where the arid climate allows more frequent development of grasshopper plagues. However, even in Florida, grasshoppers sometimes reach alarmingly high and damaging densities. Grasshopper management in Florida depends on both cultural and chemical techniques.

The Origin of Grasshopper Plagues. Abnormally high densities of grasshoppers are called outbreaks by entomologists, and plagues by the general public. Irrespective of the terminology applied, the phenomenon occurs throughout the world, and its origin is invariably related to **food** and **weather**.

Grasshoppers require warm, sunny conditions for optimal growth and reproduction. Warmth alone seems to be inadequate. Even during Florida's hot summer weather, grasshopper activity diminishes during cloudy weather. Thus, drought stimulates grasshopper population increase, apparently because there is less rainfall and cloudy weather to interfere with grasshopper activity. A single season of such weather is not adequate to stimulate massive population increase; rather, 2–3 years of drought usually precede grasshopper outbreaks. Warm winter temperatures also seem to be beneficial, because fewer overwintering nymphs and adults die.

Food is necessary for grasshopper success, and optimal weather alone in the absence of adequate food supply will prove insufficient for rapid grasshopper population growth. For outbreaks to occur, both requisites must be satisfied. Thus, some precipitation must be present at the appropriate time to stimulate plant growth, but an overabundance results in too much cloud cover. Optimal weather conditions and food supply rarely coincide in Florida, and so outbreaks are infrequent.

An example of a grasshopper outbreak in central Florida in the early 1990s illustrates the importance of the interaction of weather and food. Abnormally cold winters killed most of the citrus grown north of Orlando during the mid to late 1980s. Extensive acreage was abandoned as citrus growers moved their production farther south. This set the stage for an increase in food supply, as untended land produced luxurious growth of mixed grasses and weeds. Coincidentally, most of Florida experienced about 5 years of drought. This was a period when even the Everglades, normally a very wet environment, became very dry. The availability of extensive amounts of low-growing, mixed grass and broadleaf weed herbage in a dry, sunny environment stimulated massive grasshopper population increase in what was formerly the northern citrus growing area. Although the weather pattern was widespread in Florida, the grasshopper problem was restricted to areas that contained large quantities of the appropriate food.

Grasshopper Management. Once grasshoppers become abundant and damaging there are few options for suppression other than chemical insecticides. People often ask about the potential for biological suppression of grasshoppers. Yes, wild birds and domestic fowl, especially turkeys, readily consume vast quantities of grasshoppers, but this is not an appropriate solution for most people. There also are grasshopper disease agents under investigation, and even some that are sold commercially, but so far none has been shown to provide adequate suppression. So **biological control** remains a promising area for research, and we continue to hope for registration of an effective product, but thus far there is nothing practical. For some people, neem products are attractive. Neem products are botanical derivatives that, when applied to plants, act as a feeding deterrent, reducing damage. Also, if applied to grasshopper nymphs, neem can act as a growth regulator, disrupting the normal growth and development, and sometimes resulting in death or sterilization of grasshoppers. Although neem products are chemicals, many people take comfort in knowing that they are derived from plants, and therefore somewhat "natural." Like many natural controls, effectiveness is not always consistent.

For many people, **physical barriers** can provide some protection from damage. It is possible to screen or cover valuable plants with netting, floating row cover, or similar material to deny grasshoppers access to susceptible plants. This is suitable for small gardens, and is even applied commercially for ornamental plant production, wherein shade houses are sealed tightly

to deny access to grasshoppers. The potential for this approach is limited in scale due to the cost. For lubber grasshopper, a flightless species, physical barriers in the form of a ditch with steep sides, or a short metal or plastic wall, can be an effective impediment to grasshopper dispersal. If such a wall is contemplated, however, consider that grasshoppers can ascend vertical surfaces with amazing agility, so the top of barriers should end in a 45 degree angle, forcing the insects to fall back.

The best approach to grasshopper management is to strive to avoid problem populations through cultural manipulation of their habitat (see below). This is not always possible due to the highly dispersive nature of some species, so chemical insecticides commonly are used.

Cultural Approaches to Grasshopper Management. As discussed elsewhere (see “Grasshopper Habitats”), the habitats most favorable for grasshopper population growth and survival are open, sunny habitats containing mixed, early to mid-successional plants. Land with trees providing moderate to deep shade rarely produces large numbers of grasshoppers. Also, land that is kept mowed mechanically or by livestock grazing tends not to produce grasshoppers unless grass pasture is damaged by overgrazing and broadleaf weeds invade.

Crops planted near habitats containing dense, mixed, early and mid-successional plants may experience invasion by grasshoppers. This has been particularly evident in north and central Florida with respect to slash pine plantations. Young pine trees, once planted, are largely ignored until they are partly mature and the stand requires thinning. In the early years following pine seedling establishment, mixed grasses, broadleaf weeds and small shrubs flourish, but they usually are ignored because the fast-growing pines eventually outgrow the weeds. This results in excellent habitat for grasshoppers, and such fields may provide inoculum of damaging grasshoppers for adjacent crops (as the pine stand matures, of course, it shades out undergrowth and is poor habitat for grasshoppers). If crops are planted near young pine plantations, it is important to recognize this potential source of grasshoppers. If grasshoppers attain high densities and appear to be threatening it may be desirable to mow or plow between the pines, depriving grasshoppers of habitat and disrupting their biology. Alternatively, insecticide can be applied to the pine plantation, or perhaps only the border of the plantation, thereby establishing an insect-free buffer between the source of grasshoppers and the susceptible crops.

There is one important exception to the pattern described above, and this involves the eastern lubber grasshopper, *Romalea microptera*. This unusual, flightless grasshopper is one of the more common pests in Florida, and is found damaging vegetable gardens, ornamental plantings, and citrus groves in a variety of habitats. However, despite its widespread occurrence in the late nymphal and adult stages, it seems to emanate annually from low, moist, dense habitat, including areas that include considerable tree overstory.

Insecticides for Suppression of Grasshoppers. Chemical insecticides can be applied in **liquid** form, by application directly to the grasshoppers or to the plants they will walk or feed upon. Insecticides can also be applied to bran flakes, and distributed as a **bait**. Both approaches, but particularly the latter, are difficult to use in Florida due to dense vegetation. If insecticides are to be used, it is advisable to apply the chemicals when the grasshoppers are young. Small insects are much easier to kill than large, and grasshoppers are notoriously difficult to kill under any conditions. Also, because the grasshoppers usually develop in surrounding vegetation it is usually best to take the “battle” there, and apply insecticides to the young grasshoppers before they disperse into crops and cause damage.

What is a Species?

Often it is difficult to decide whether populations differing slightly from one another should be regarded as different species, or simply as varieties or subspecies. This is especially true with populations that are geographically isolated.

Most biologists define **species** as groups of actually or potentially interbreeding populations that are reproductively isolated from other groups. Thus, if populations of grasshopper X. a in southeast Florida breed successfully with populations in southwest Florida and central Florida, we consider them to be the same species. If species X. a from central Florida does not successfully breed with grasshoppers from north Florida in the regions where both occur we consider the northern populations to be a separate species, perhaps designated as X. b. But what do we make of grasshoppers that occur only in the western panhandle area of Florida if they do not

breed successfully with our northern *X. b* grasshoppers? Are they another species, perhaps *X. c*, or could they be geographically separate populations of our southern and central Florida species, *X. a*? Because the geographically separate populations do not have the opportunity to interbreed we cannot easily test the definition of a species.

Florida has many grasshoppers with strong powers of flight, and broad dietary habits, allowing them to move freely across the landscape. When such grasshoppers segregate into separate populations, and attain the different appearances or behaviors that normally accompany reproductive segregation, we have no difficulty designating them as separate species. However, Florida also has many short-winged, flightless grasshoppers that dwell on isolated sand ridges. During ancient times when the sea level was higher, these ridges were islands, and even now are “**biological islands**,” with unique flora. Thus, there have been, and remain, isolated populations of grasshoppers incapable of reproduction because the populations of one “island” do not come into contact with the population of other “islands.” But are they reproductively isolated? Have they diverged sufficiently to be considered true species?

Often it is difficult to know with certainty whether different populations constitute different species. However, if they differ greatly in appearance or behavior, especially if the differences are associated with reproductive structures or mating behavior, we tend to consider them separate species. There is some disagreement among scientists, of course, over whether certain populations are sufficiently different to be considered separate species. In this manual we have taken a conservative approach, consolidating some very similar populations that others have considered to be separate species into a smaller number of species.

Why is it sometimes difficult to determine if populations represent different species? As previously mentioned, speciation is based on behavior, physiology, and genetics, as well as appearance, or **morphology**. Only morphology is relatively easy to assess and to portray to others. Therefore, most taxonomists depend on morphological characters to distinguish among species. Unfortunately, there can be considerable variation in morphology within even a small geographic area, and immense variation over the entire range of an insect. Many scientists have described grasshoppers as new species only to discover later that the new “species” was only a morphological variant of another species. Grasshoppers exhibit considerable variation in color and wing length, accounting for many of the erroneous species descriptions. Often the sexual organs are used to distinguish among species, because these characters relate directly to reproductive compatibility and population genetics. However, even here it is sometimes difficult to know how much difference in genitalia constitutes enough to cause physical incompatibility and result in genetic isolation.

Exact determination of species numbers is probably a fruitless enterprise, as **speciation** is a dynamic phenomenon, with new species slowly evolving in some areas, and extinction probably occurring in others. Particularly in the case of Florida, where land conversion and natural habitat destruction are frequent, extinction is a real possibility for some species of grasshoppers. Perhaps the best example of this is *Melanoplus puer* and its closely related species. *Melanoplus puer* has several races or subspecies that differ only slightly, but most are separated geographically and seem to be in the process of evolving into separate species. Some of *M. puer*'s close relatives are only marginally different from it, and likely evolved in relatively recent times. Also, such species as *Melanoplus adelogyrus*, *M. apalachicola*, *M. gurneyi*, *M. indicifer*, *M. pygmaeus* and *M. withlacoocheensis* apparently occur in small areas. *Melanoplus gurneyi* occurs in a fairly small area in the western Panhandle area of Florida, and *M. indicifer* in an even smaller area near Jupiter on the east coast of Florida. If extensive development occurs in these areas the probability of such species surviving is remote.

Collecting and Preserving Grasshoppers

Why Collect Grasshoppers? Grasshoppers are among the best insects to collect. You do not have to travel far or to exotic habitats to collect some, and often they are numerous. They commonly are large, at least by insect standards, which makes them relatively easy to handle and identify. Identification ranges from quite simple to requiring close, detailed examination, so there are various levels of challenge. They also vary in difficulty of collection; some species are easy to obtain whereas others require considerable searching or travel to a specific location in the state. Grasshoppers are inherently interesting, and often strikingly beautiful if you take the

time to look closely. Few people have seen the myriad of hues on the hind wings of bandwinged grasshoppers. Fewer yet have examined the inside of the hind legs of these species for the striking array of colors, including bands of yellow, orange, red, blue, and black. Finally, there is considerable physical and intellectual challenge in netting these cunning species. The grasshoppers that respond to your net by flying 100 meters away, or 10 meters up into a tree, or to rest on emergent vegetation in a pond frequented by alligators, will quickly earn your respect!

Collection. Grasshoppers are easily collected and preserved. An insect net is usually required for collection, especially for the bandwinged and *Schistocerca* species. Other than a net, no special equipment is required. Because immature stages are frequently collected, have a cage or other container available to rear the nymphs to the adult stage.

It is easy to find habitats suitable for grasshopper collecting. In fact, this is one of the advantages of collecting grasshoppers; nearly all habitat types support interesting and unique species. It is possible to stop along the side of any road in Florida that is bounded by grass, weeds, and low-growing or open vegetation, and find large numbers of grasshoppers. Collecting can be done throughout the year, but the best period to collect is April to November. Most landowners are extremely cooperative and freely allow insect collecting, but if the landowner can be found it is best to inquire before collecting. National and state parks usually prohibit removal of anything from the property, so inquire in advance and request a permit if you want to collect in such habitats.

Preservation. Grasshoppers normally are preserved by killing, pinning, and drying. Grasshoppers can be killed by freezing or with chemicals. The easiest and safest technique is to place insects into a freezer for several hours. They can also be killed by exposing them to a small amount of toxic fumigant such as ethyl acetate. Toxicants are usually used in conjunction with a specially prepared killing jar. The killing jar has a layer of plaster of paris poured in the bottom of the jar. Once ethyl acetate is poured onto dried plaster of paris, the chemical is absorbed by the plaster, and the jar will produce toxic fumes for several days.

Usually it is not desirable to kill nymphs because they lack the characters needed for identification. Also, due to their soft body they do not preserve well in a dry state. They are best placed in alcohol to prevent excessive distortion.

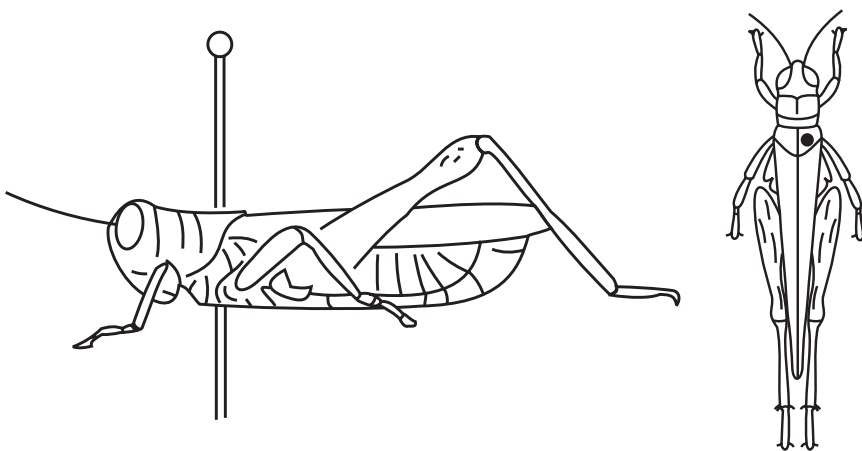

Pinned grasshoppers showing proper placement of pin.

To mount adult grasshoppers on a pin, insert a pin into the dorsal surface, with the point protruding from the ventral surface. The preferred location for pinning is usually the posterior area of the prothorax, and to the right of the midline. The grasshopper is pushed up on the pin so that not only the end, but a small amount of the shaft is protruding. This gives ample room to pick up the dead grasshopper without touching the insect's body. Below the grasshopper body, collection data are provided via a label. This is accomplished by writing or printing data on stiff paper, and cutting the label to a small rectangle. A pinning block often is used to align the insect body and label(s) to standard heights. Data that should be included on the label include the date of collection, place of collection, and collector's name. Ecological data such as

habitat or host plant may also be included. Pins vary in size and quality. It is highly desirable to use rustproof insect pins. Insect pins are longer and sharper than standard pins, allowing attachment of labels and easy mounting. Insect pins and all other collection and preservation equipment are available from biological supply houses.

To fully appreciate the beauty of the bandwinged species, and to assist in identification, spread at least one forewing and hind wing. The usual procedure is to spread the left forewing perpendicular to the grasshopper body. Similarly, the leading edge of the hind wing is spread perpendicular; this results in full extension of the remainder of the hind wing. Species other than bandwinged grasshoppers are rarely spread, though if it is done the spread wing may aid identification.

To properly spread the grasshopper's wings, some support is needed to keep the wings elevated and flat. A spreading board is usually used to provide wing support. A spreading board consisting of Styrofoam or another suitable pinning surface should have a strip of similar material glued on part of the board, so that one surface is higher than the other. Thus, the lower pinning board is used to support the grasshopper body on its pin, and the elevated portion is used to support the wing. Strips of paper and pins are used to hold the wing in place. Whether or not the grasshopper's wings are spread, grasshoppers must be dried to aid preservation. Drying can be accomplished by placing the pinned insect, often with its wings spread, in an oven at low temperature until the subject is dry and stiff. Once dried, the wings, antennae, and legs cannot be moved without breaking, so it is important to get the body parts aligned before drying.

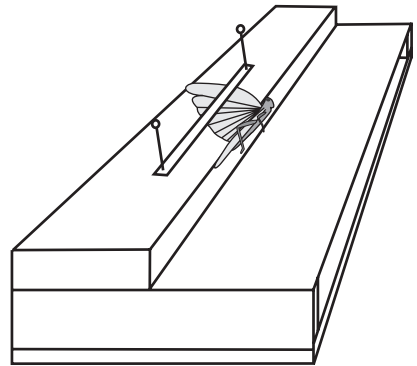

Grasshopper with wing spread on spreading board.

The color of grasshoppers tends to fade as the insect dies. This is difficult to prevent. Much of the discoloration is due to the accumulation of body oils at the surface of the body. The oil can be extracted, preventing some of the color change. To extract oils, place the dried insect on its pin in a bath of acetone. Usually a few hours is adequate; prolonged extraction causes the insect body to bleach to a light color.

If you are going to make an insect collection you need suitable storage. Storage requires nothing more than a tight box with pinning material in the bottom. However, it is imperative that the box be tight, or carpet beetles and cockroaches will gain access and devour the pinned insects. To help prevent damage to specimens, you can place moth balls or moth crystals in the box with the specimens. This will kill any insects that gain access, particularly ants, cockroaches, and book lice.